

DRF02020

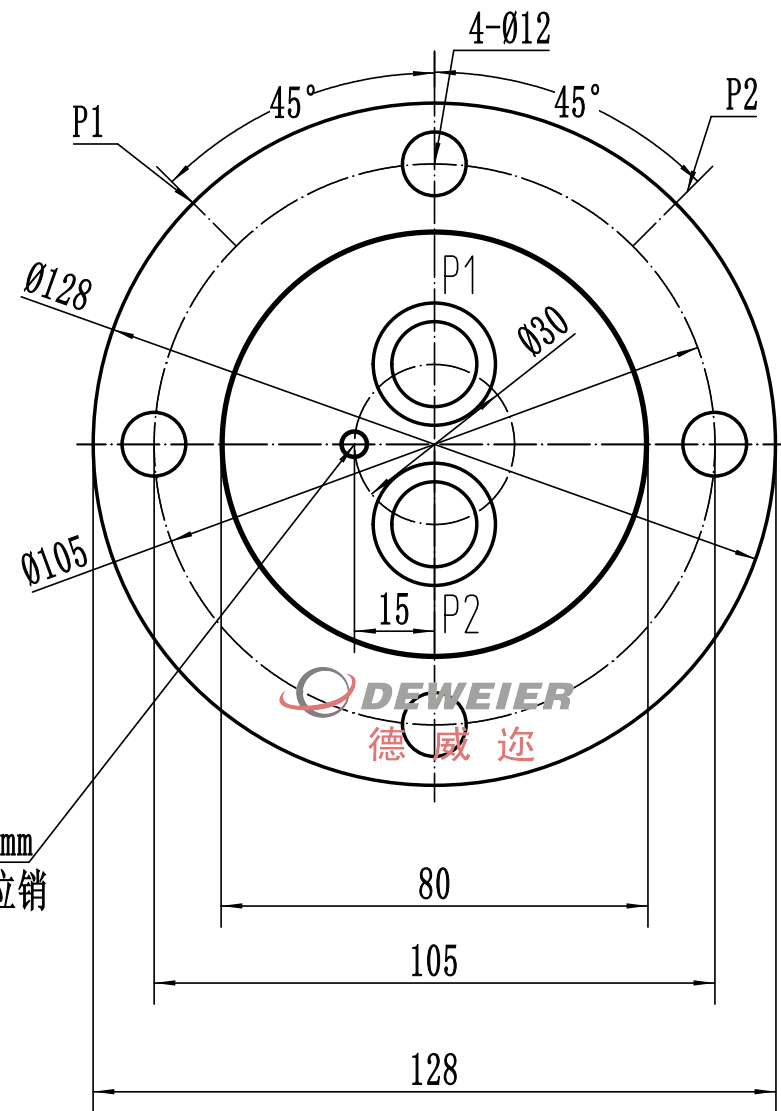

Ø4h6-6mm  
Pin 定位销

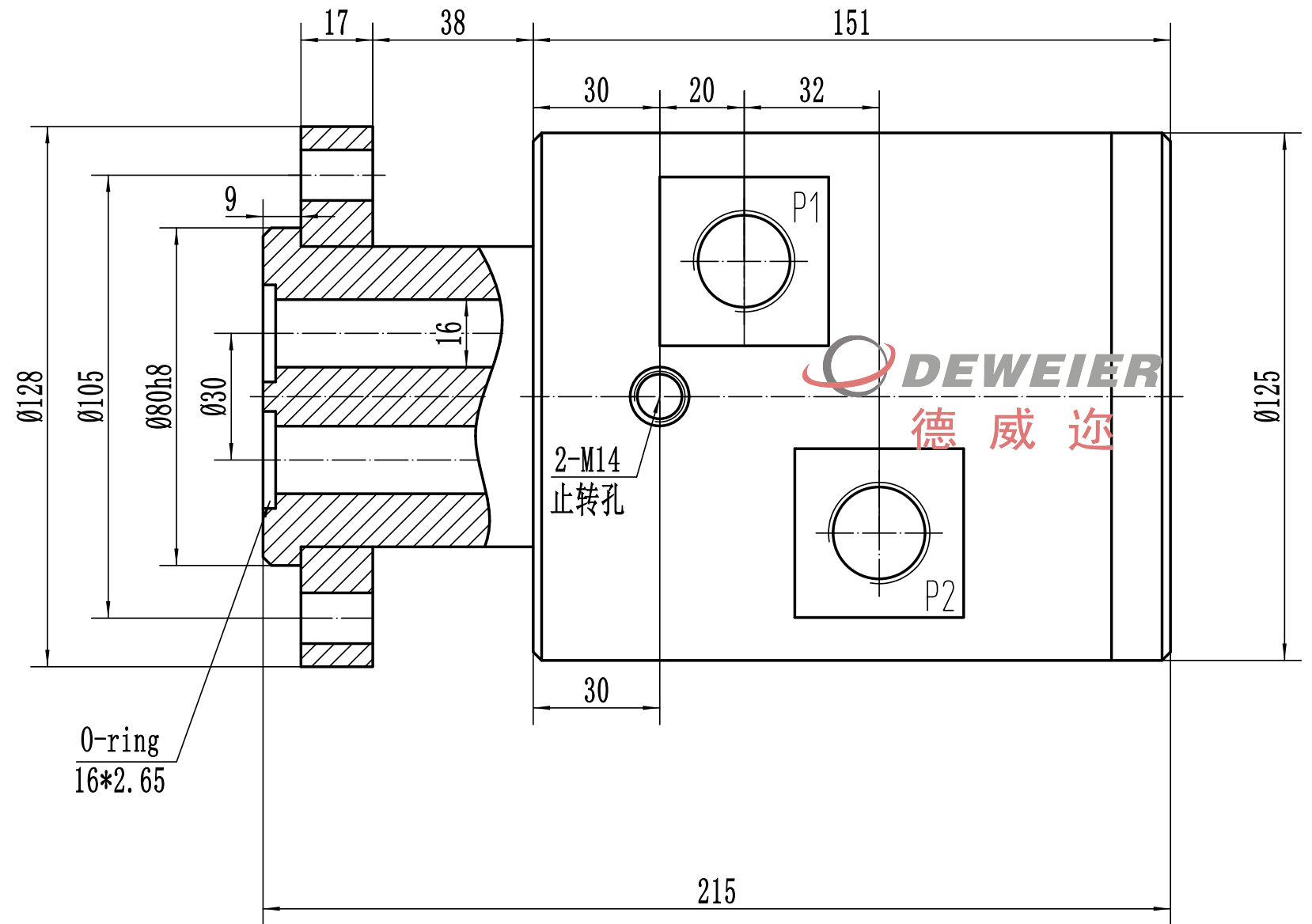

O-ring  
16\*2.65

枣庄市德威迩机械科技有限公司

Dewel Machinery Technology Co., Ltd.

技术参数 TECHNICAL PARAMETERS

使用参数 Working parameters

MAX. PRESSURE	32MPa; (<320Bar)	介质 Fluid	空气 Air	压力 Pressure	2.0MPa;	温度 Temperature	80℃	转速 Rotating speed	60RPM
MAX. SPEED	250RPM;	水 Water	4.0MPa;	80℃	30RPM	液压油 Hydraulic oil	7.0MPa;	80℃	30RPM
TEMPERATURE	-20℃----+80℃		25MPa;	80℃	10PM				
MEDIA TYPE 介质	Hydraulic oil/water/air 液压油/冷却水/压缩空气								

备注: 技术参数数据为最大值, 并不能同时使用;  
The technical parameter data is the maximum value and cannot be used of the same time.

DEWEL DRF Series are multi-way rotary joints designed to carry multiple media continuously for low-speed and high-pressure equipment. They are used on machining center revolving tables, rotating platforms, coiling machines, converters, ladle turret, hydraulic machinery, multi-way high pressure controller and etc.



德威迩企业官网



德威迩业务号

<p>多通道旋转接头 Multi-Passage Rotary joint</p>		<p>德威迩</p>
<p>E-mail: sddeweier88@163.com</p>		
	<p>TEL: +86 632 5822778</p>	<p>www.sddeweier.com</p>
	<p>TEL: +86 632 5832779</p>	
<p>P/N: DRF02020-G3/4''</p>		