

DRF02010

A

B

C

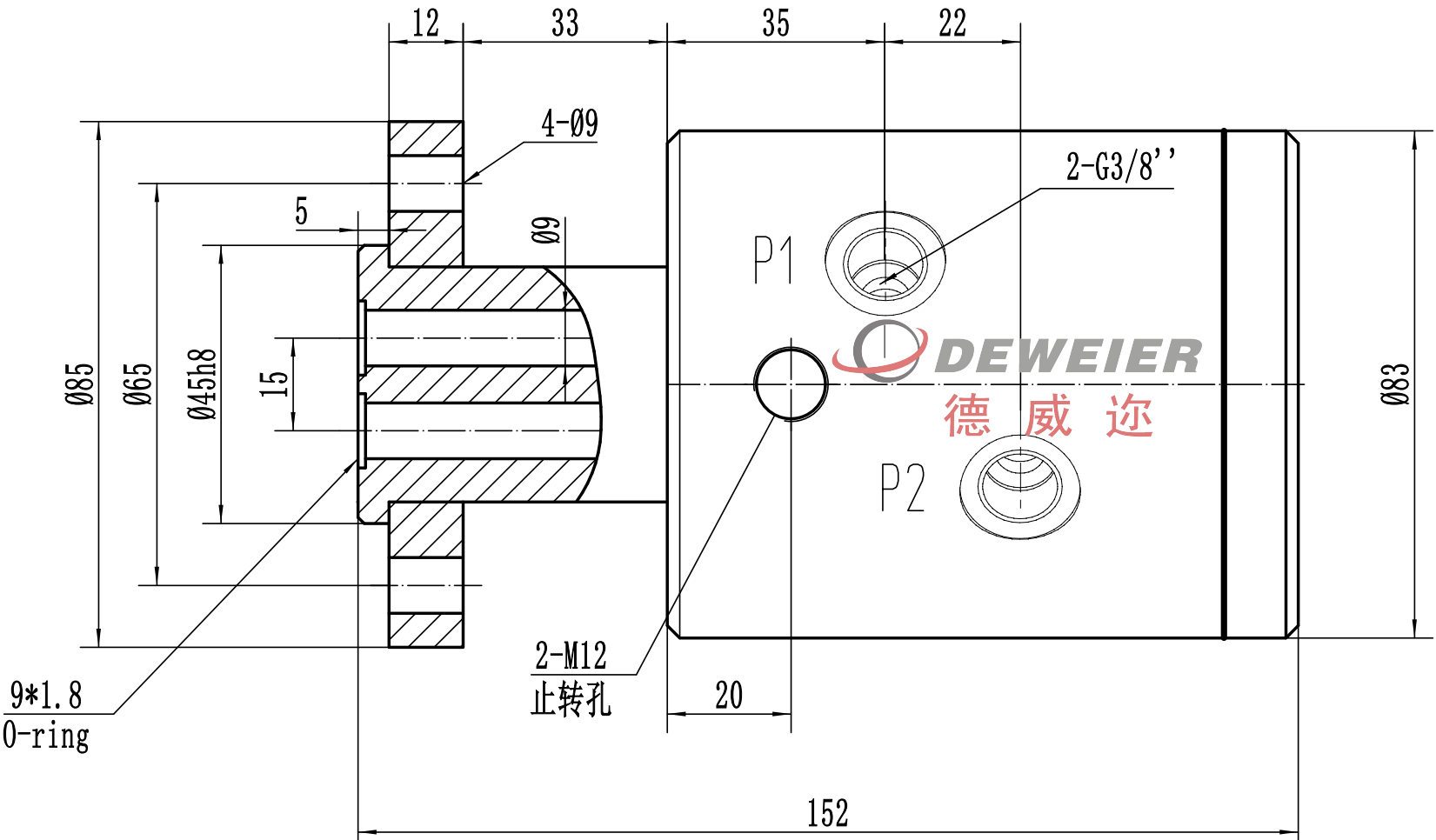
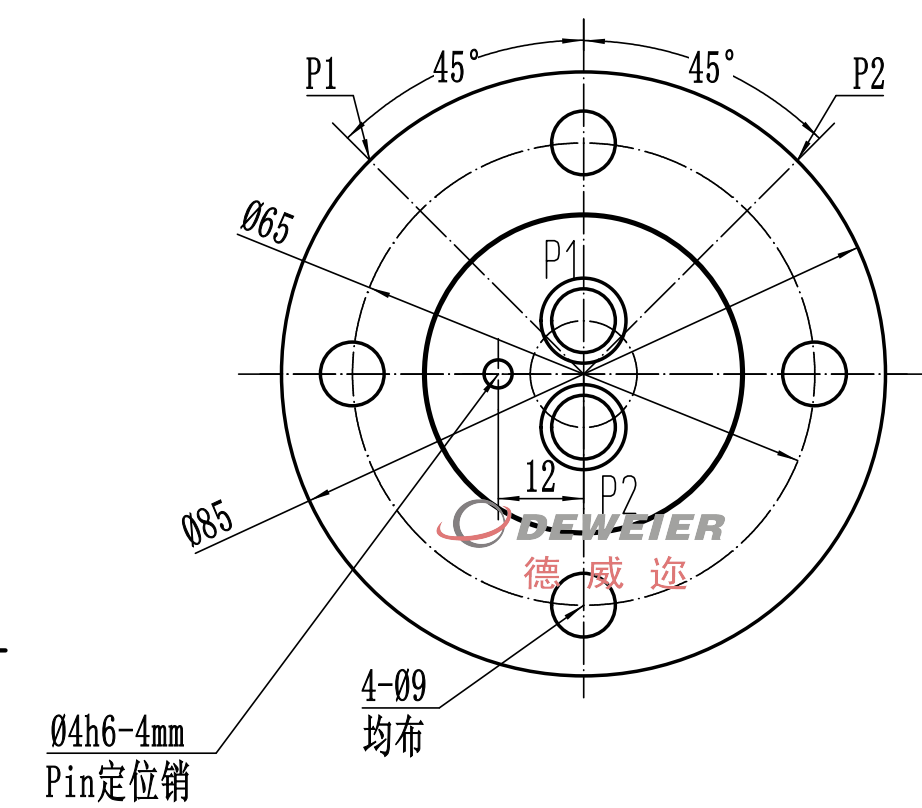

枣庄市德威迩机械科技有限公司

Dewel Machinery Technology Co., Ltd.

技术参数 TECHNICAL PARAMETERS

使用参数 Working parameters

MAX. PRESSURE	32MPa; (320Bar)
MAX. SPEED	250RPM;
TEMPERATURE	-20℃----+80℃
MEDIA TYPE 介质	Hydraulic oil/water/air 液压油/冷却水/压缩空气

介质 Fluid	压力 Pressure	温度 Temperature	转速 Rotating speed
空气 Air	2.0MPa:	80℃	200RPM
水 Water	4.0MPa:	80℃	100RPM
液压油 Hydraulic oil	7.0MPa:	80℃	100RPM
	25MPa:	80℃	20RPM

德威迩公司 DRF02 系列旋转接头是一种专门具有多个通道，可连接提供多种介质给低速高压旋转设备的一种旋转接头。服务于加工中心旋转工作台、旋转平台、卷取机、转炉、大包回转工作台、液压机械及多通路高压控制器等设备。
DEWEL DEF02 Series are multi-way rotary joints designed to carry multiple media continuously for low-speed and high-pressure equipment. They are used on machining center revolving tables, rotating platforms, coiling machines, converters, ladle turret, hydraulic machinery, multi-way high pressure controller and etc.

备注：技术参数数据为最大值，并不能同时使用；
The technical parameter data is the maximum value and cannot be used at the same time.



多通道旋转接头
Multi-Passage Rotary joint

DEWEIER 德威迩

E-mail: sddeweier88@163.com www.sddeweier.com

TEL: +86 632 5822778
TEL: +86 632 5832779

P/N: DRF02010-G3/8''